

**500-EXCELLENT SERIES BASIC-MODELS**

Ineffective and unhygienic manual handling of food waste is eliminated by choosing a disposer with both capacity and power to grind the type of food waste produced in galley and kitchen working areas.

The 500 EXCELLENT Series has been designed to meet modern demands for the handling of food waste wherever it is produced in the kitchen.

Disposers from the 500 EXCELLENT Series are included in a range of models for mounting into existing working top, sink unit, washing line and for freestanding installations.

The grinding unit of special cast steel alloys and its unique shaft seals, together with IP55 classified motors ensure that Disperator's EXCELLENT series gives long and trouble free service.

To comply with EU Machine Directive, the BASIC model must be assembled with an ATF-, ATV-, BS-, HK-, MI- or DRR-K-assembly before CE-certification is given. Product sheets giving detailed information, about these assemblies are forwarded upon request.

The Disperator 500 Excellent Series has Det Norske Veritas (DNV) Approval for compliance with IMO MARPOL 73/78 ANNEX V for disposal of ground food waste into the open sea.

Further details are specified overleaf.

**Disperator AB**

Mälärvägen 9, SE-141 71 Segeltorp, Sweden  
Tel +46 8 724 01 60, Fax +46 8 724 60 70  
info@disperator.se, www.disperator.se



Ref: 500/Prod/Eng/091014

## 500-EXCELLENT SERIES BASIC-MODELS

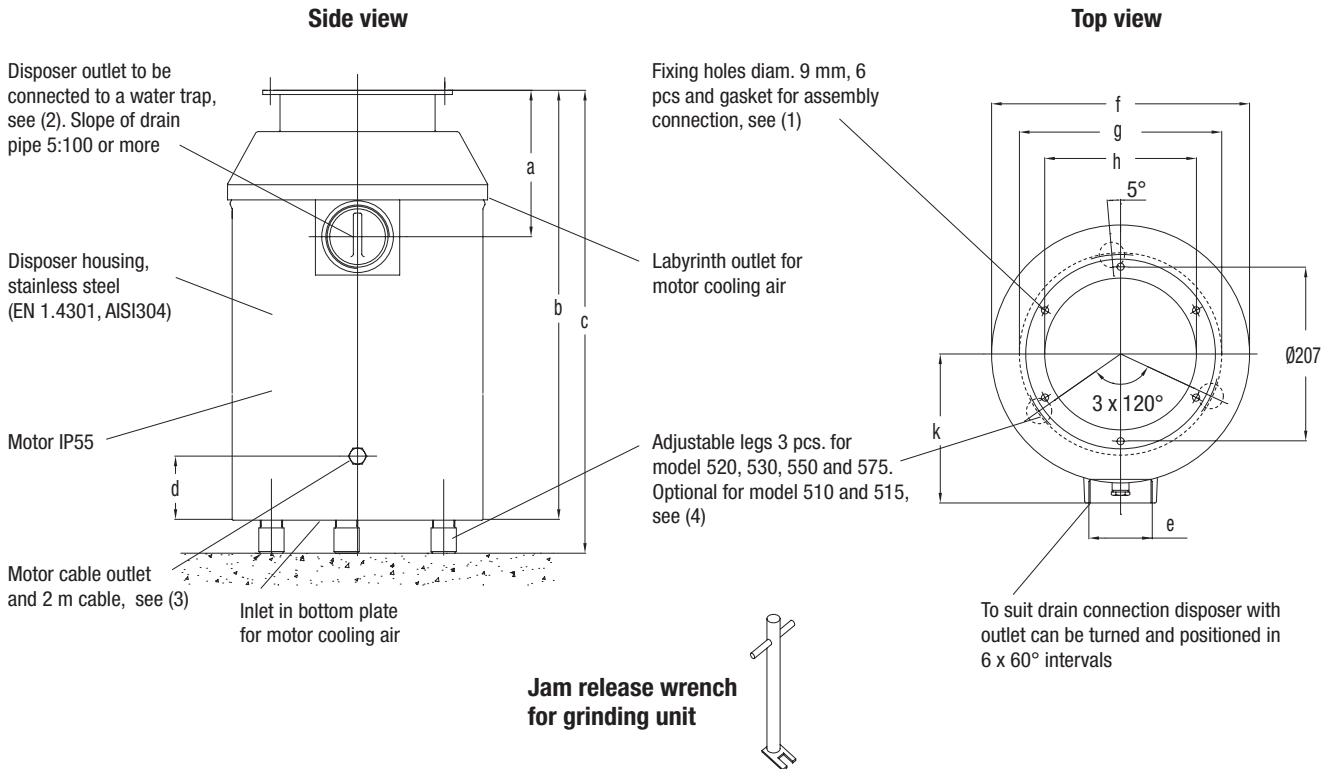

All measurements in mm

Technical Specification	510	515	520	530	550	575
Normal capacity, kg / hr	300	400	500	700	850	1000
Electrical power, kW	0,75	1,1	1,5	2,2	4,0	5,5
<i>Rated current, A for:</i>						
230 V / 3 ph. / 50 Hz	3,7	4,6	5,9	9,0	14,4	19,7
400 V / 3 ph. / 50 Hz	2,1	2,6	3,4	5,2	9,0	11,5
440 V / 3 ph. / 60 Hz	2,1	2,4	3,5	5,2	7,5	11,6
Other 3-ph voltages available	1-ph 220-240V, 50/60Hz also available for models 510 and 515					
Control voltage	For marine installation the same as motor voltage. For land installation 230V / 50HZ					
Fuse rating, slow	10 A	10 A	10 A	16 A	16 A	25 A
Gross / net weight, kg	29 / 26	32 / 29	37 / 34	45 / 42	48 / 45	57 / 54
Measurement a	151	151	151	176	176	176
Measurement b	425	425	568	545, see (5)	545, see (5)	640
Measurement c	See (4)	See (4)	591-715	570-635, see (5)	570-635, see (5)	665-730
Measurement d	40	40	40	75	75	75
Measurement e	2 "	BSP,	Female	2 1/2 "	BSP,	Female
Measurement f	253	253	253	310	310	310
Measurement g (legs)	see (4)	see (4)	204	236	236	236
Measurement h (inlet)	160	160	160	174	174	174
Measurement k	150	150	150	176	176	176

- (1) For CE-marking an approved assembly from DISPERATOR or other manufacturer is needed above disposer inlet.
- (2) Installation material needed but not incl. in standard delivery are electrical connection terminal / main switch and water trap. Can be ordered from DISPERATOR.
- (3) For connection to start & stop controller (IP55, incl. overload protector) placed on wall / bulkhead. Controller to be connected to terminal / main switch, see (2).
- (4) Suspended under the assembly and therefore as standard without legs. Legs available as option – and then with same measurements b), c) and g) as model 520. Models 510, 515 1-ph have same measurements b), c) and g) as model 520.
- (5) Short version (b = 510 mm and c = 522 –593 mm) available as option. Long version (b = 640 mm and c = 665–730 mm) also available as option.
- (6) Installation, operation and service instructions are together with this product leaflet included in delivery.

## Disperator AB

Mälurvägen 9, SE-141 71 Segeltorp, Sweden  
 Tel +46 8 724 01 60, Fax +46 8 724 60 70  
 info@disperator.se, www.disperator.se

Ref: 500/Prod/Eng/091014